

CS 202: Automata Theory and Formal Languages

Assignment 1

January 30, 2015

1. Write a grammar to generate the strings in the language $L = \{ 0^m 1^n \mid 0^{m+n} \text{ where } m, n \geq 1 \}$
2. Write a grammar to generate the strings in the language $L = \{ a^m b^n \text{ where } m \neq n \}$
3. Write a grammar to generate strings in the language $L = \{ 0^a 1^b 2^c \text{ with } |a-b|=c \text{ where } a, b, c \geq 0 \}$
4. Design a finite automata for accepting strings of zeroes and ones containing equal number of zeroes and ones and no prefix of the string should contain two more zeroes than ones or two more ones than zeroes
5. Design a deterministic finite automata for accepting all possible strings of zeroes and ones not containing 101 as a substring
6. Design a deterministic finite automata which will accept those strings of binary numbers which are divisible by 3
7. Consider the DFA given in Figure 1 and reduce number of states in the DFA preserving its language acceptance
8. Covert the NFAs shown in Figure 2 into their equivalent DFAs
9. Design an NFA for the language $L(M) = \{ 01^n \text{ where } n \geq 2 \}$ and convert into its equivalent DFA
10. Design a DFA for the language $L(M) = \{ 0(01)^n \text{ where } n \geq 0 \}$
11. Design a mealy machine that generates X as output if the string is starting with 1 and ending with two consecutive 0's and produce output Y otherwise
12. Consider the minimized DFA of Q7 and obtain the equivalent regular expression for it using the procedure for conversion (need to show all the steps)

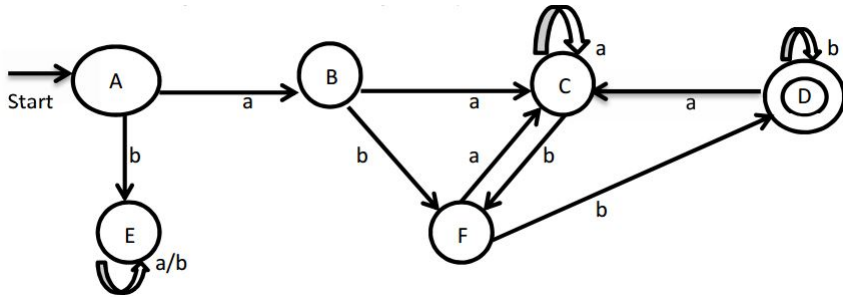

Figure 1: DFA for Minimization

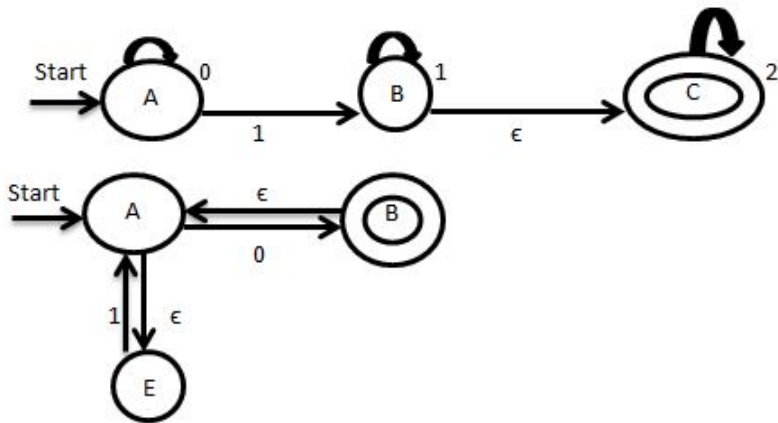

Figure 2: NFA for conversion into DFA